

PAK-M with Standard Dust Separator

PAK-M

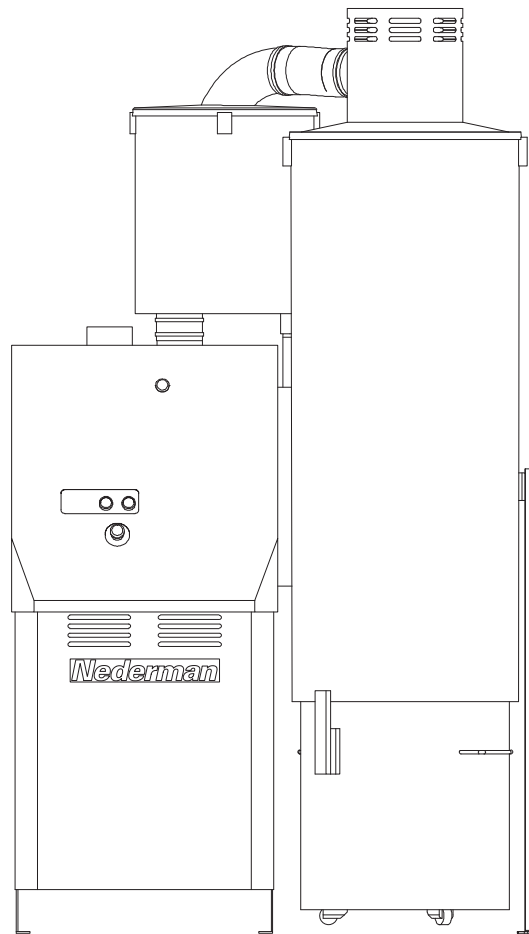

Original installation and service manual

EN INSTALLATION AND SERVICE MANUAL

Table of contents

Figures	4
1 Preface and safety	12
1.1 PAK-M specifics	12
1.2 Overall PAK-M safety	12
2 Installation	13
2.1 Transport and delivery check	13
2.2 Pre-installation	13
2.3 Main installation	14
2.4 Duct installation	14
2.5 Electrical installation	14
2.6 Compressed air installation	15
2.7 Installing a secondary filter	15
2.8 Main parts	15
2.9 Accessories	15
2.10 Pressure measuring points and connections	16
2.11 Technical data	16
3 Service and maintenance	18
3.1 Maintenance schedule	18
3.2 Inspections	18
3.3 Changing the main filter package or replacing a filter bag in the main filter	18
3.3.1 Changing the main filter package	19
3.3.2 Changing a filter bag in the main filter	19
3.4 Tilting the Dust Separator	19
3.5 Changing the secondary filter	20
4 Appendix A: Installation protocol	21
5 Appendix B: Service protocol	23

Figures

1

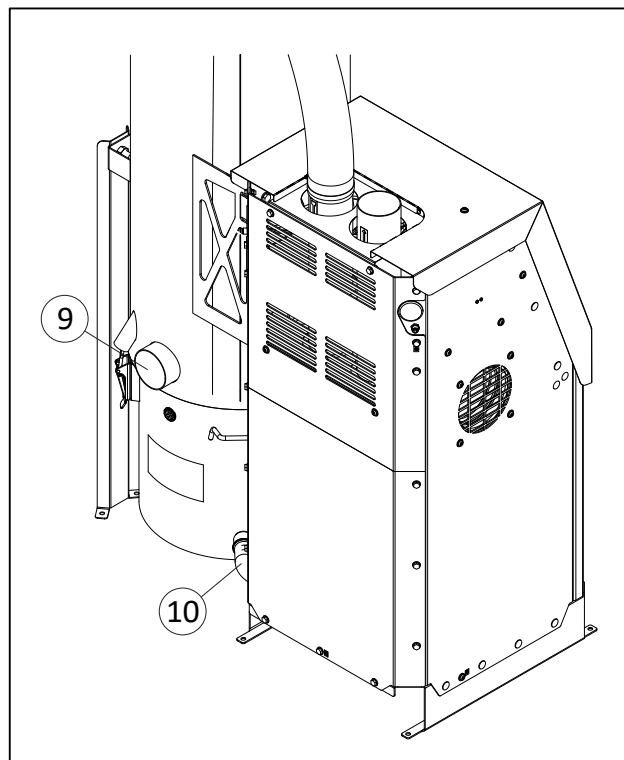
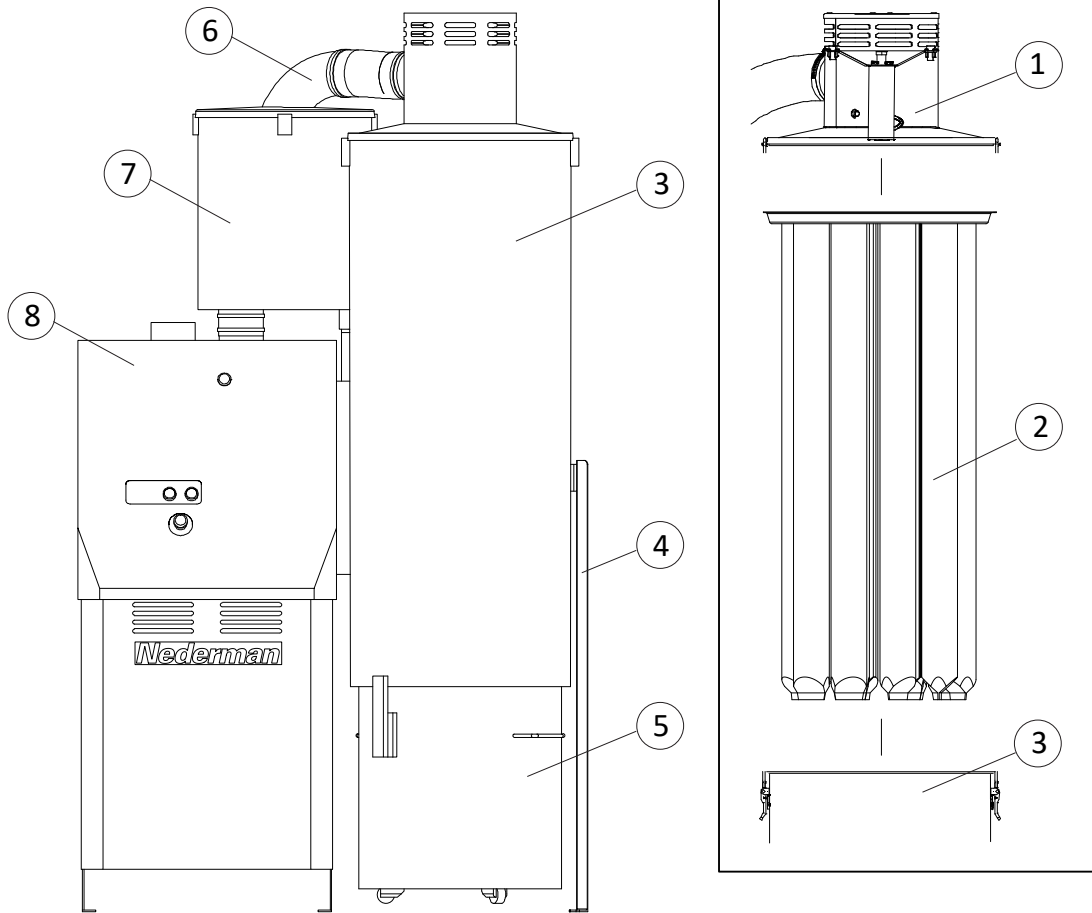

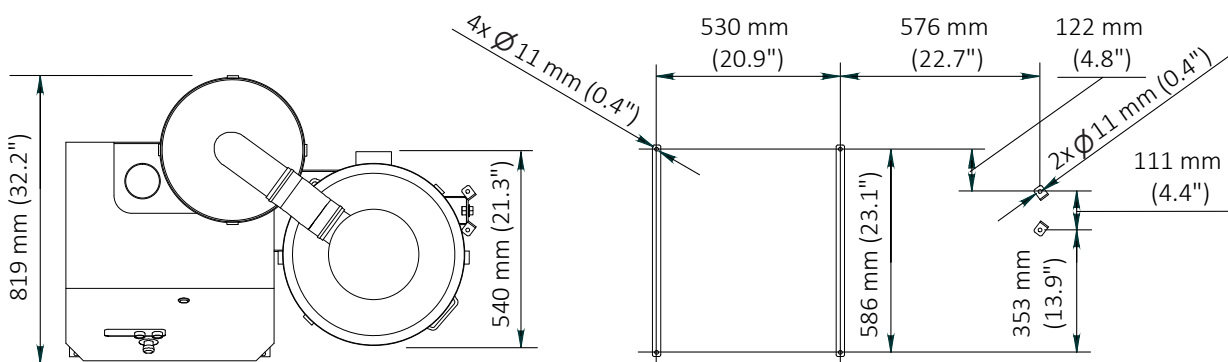
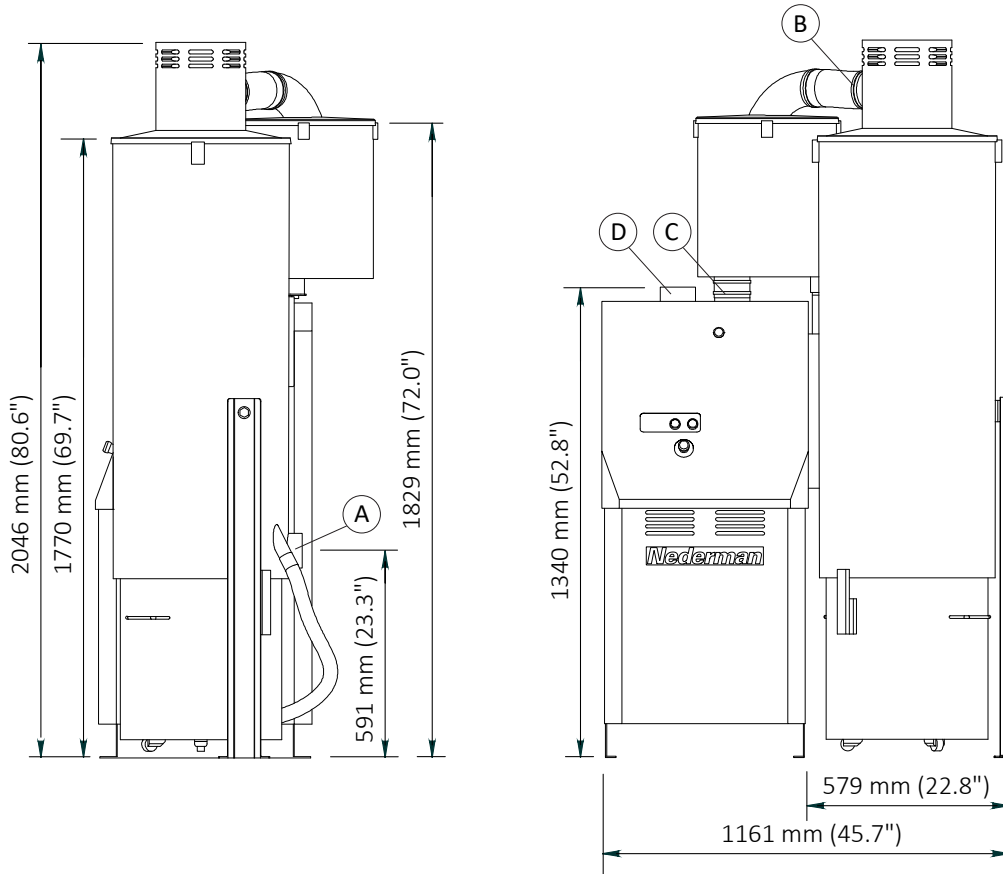

3

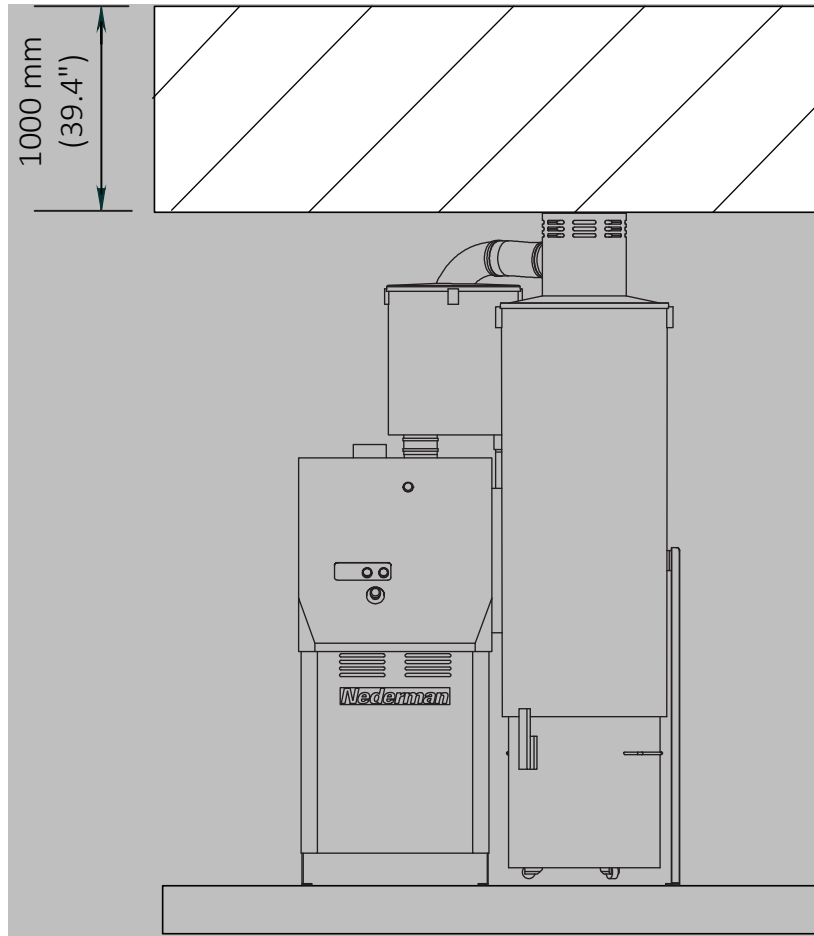

4

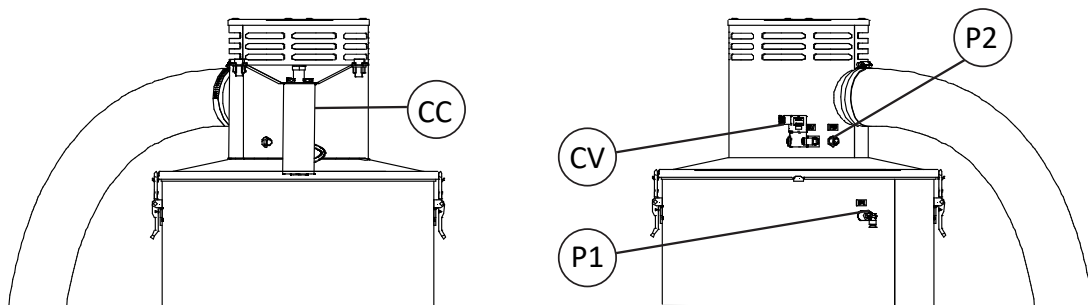

5

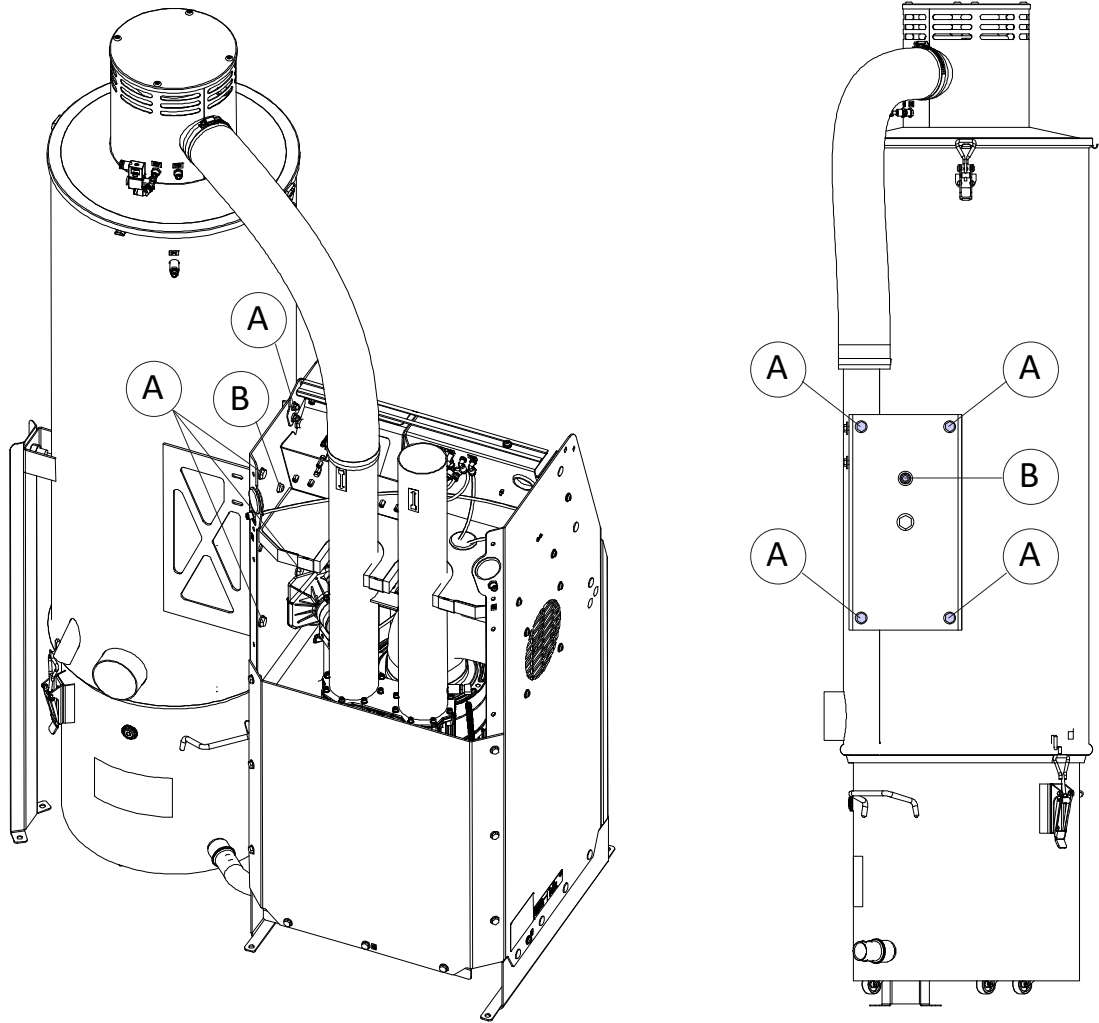

6

1

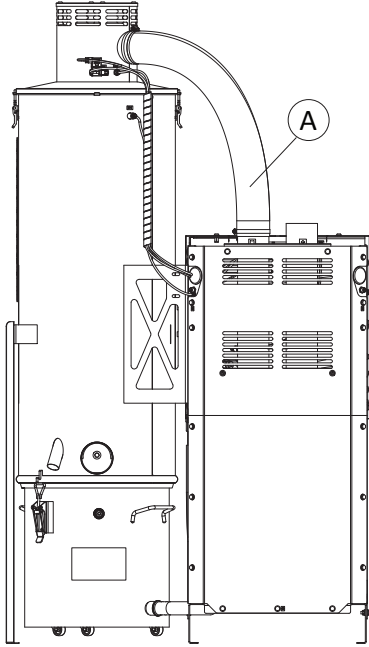

2

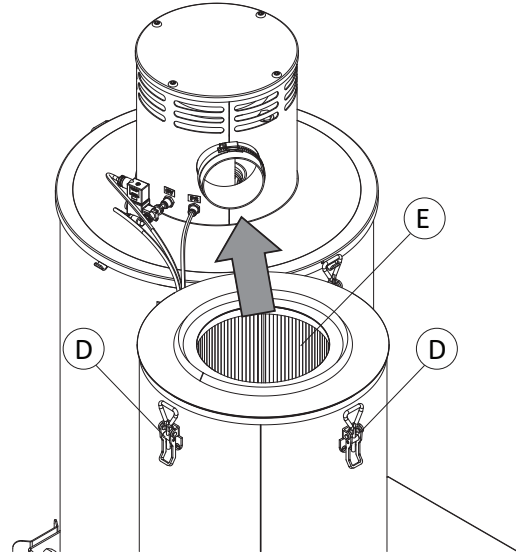

3

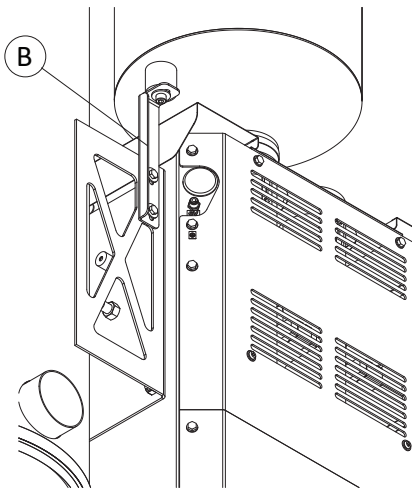

4

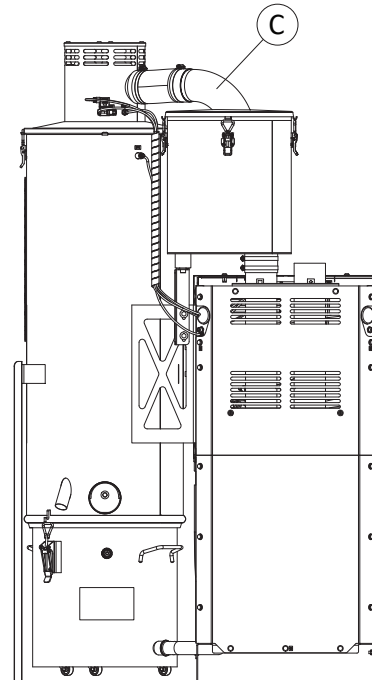

7

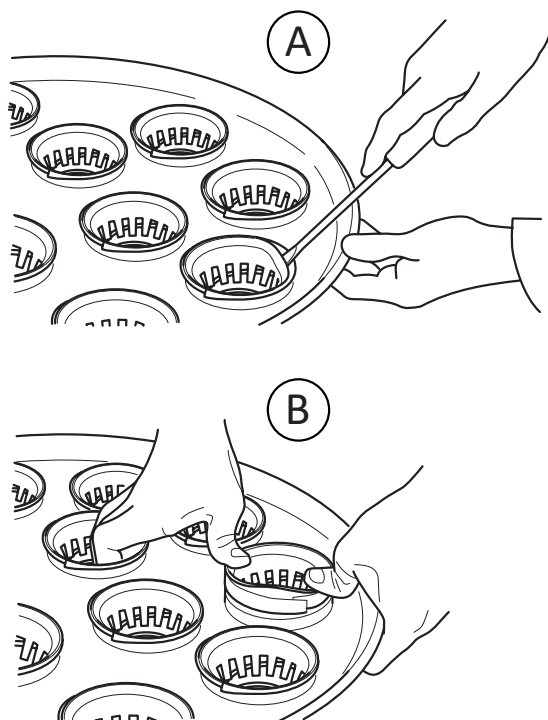

8

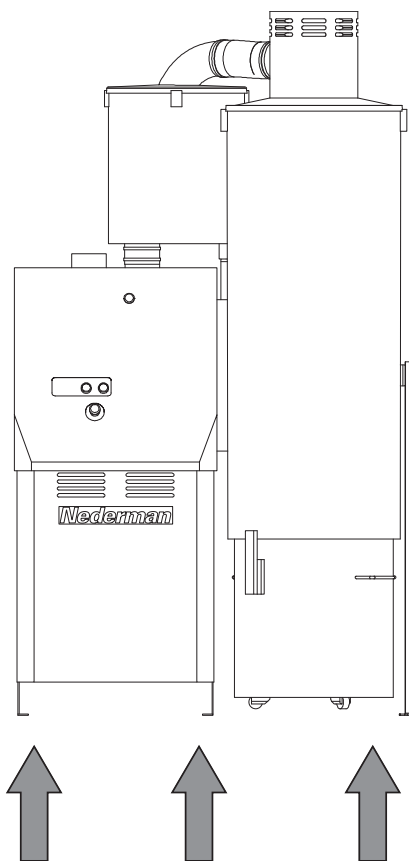

9

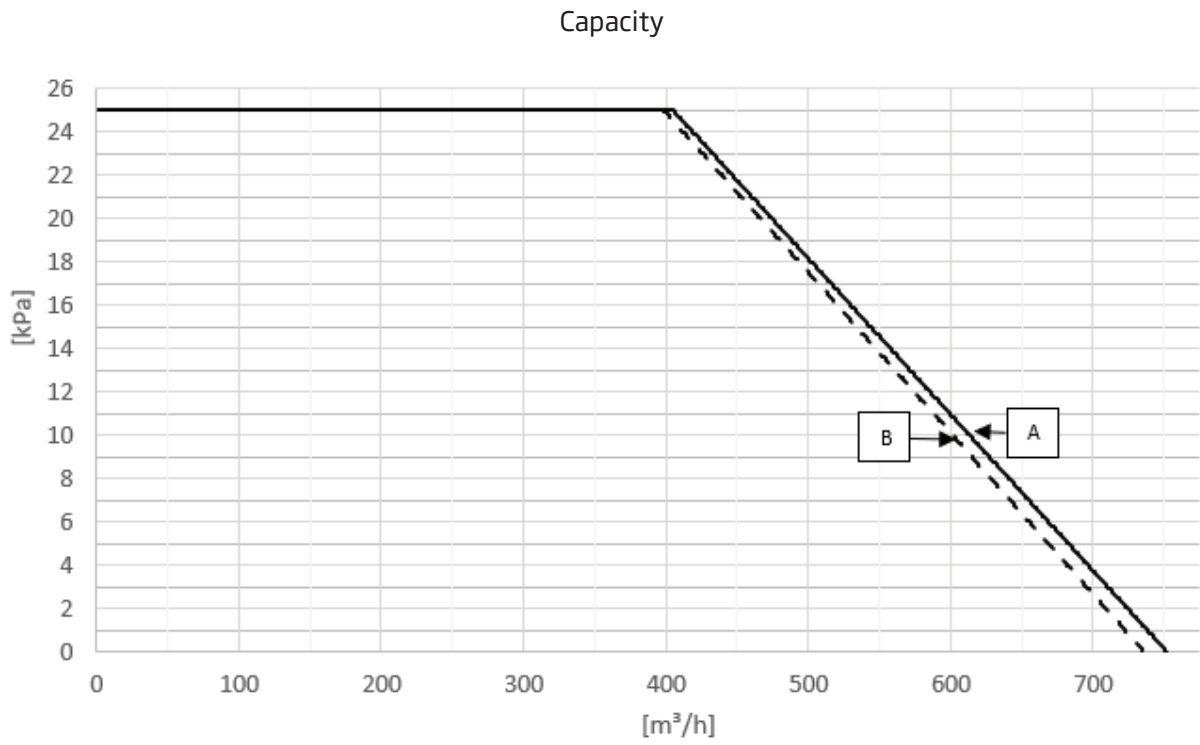

10

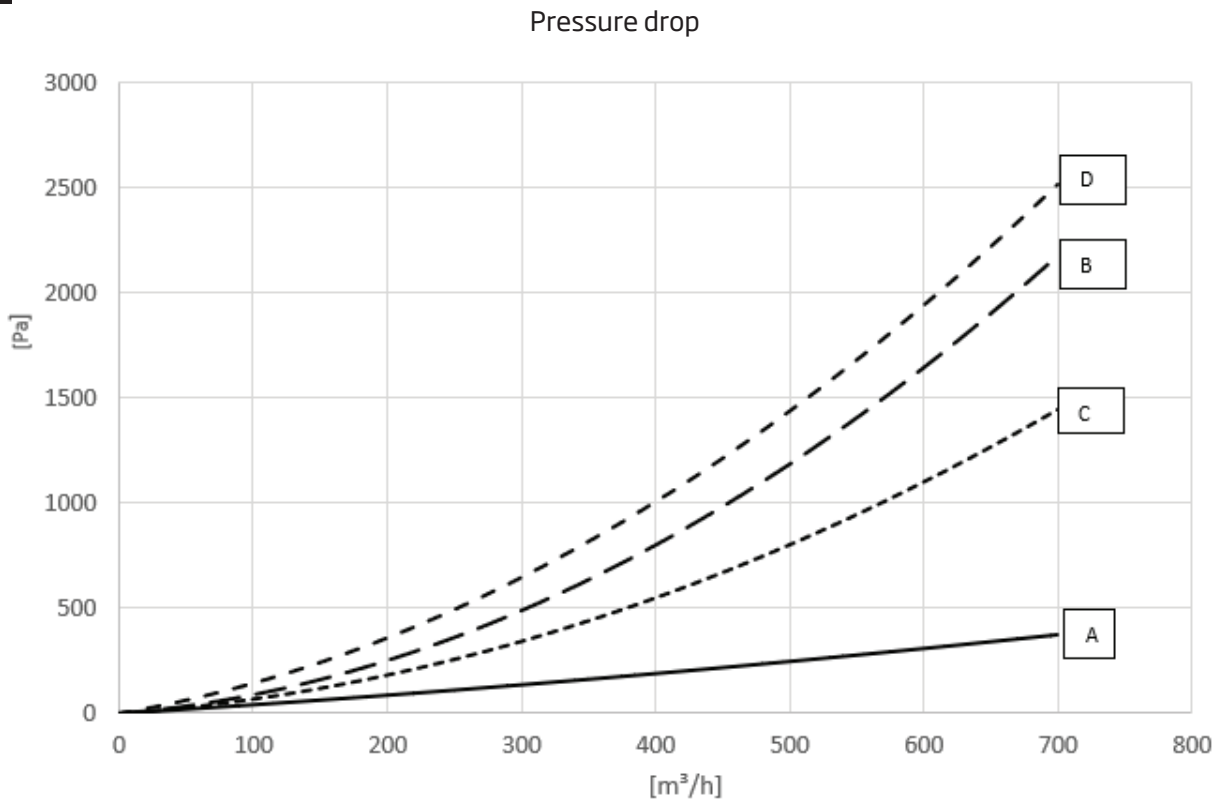

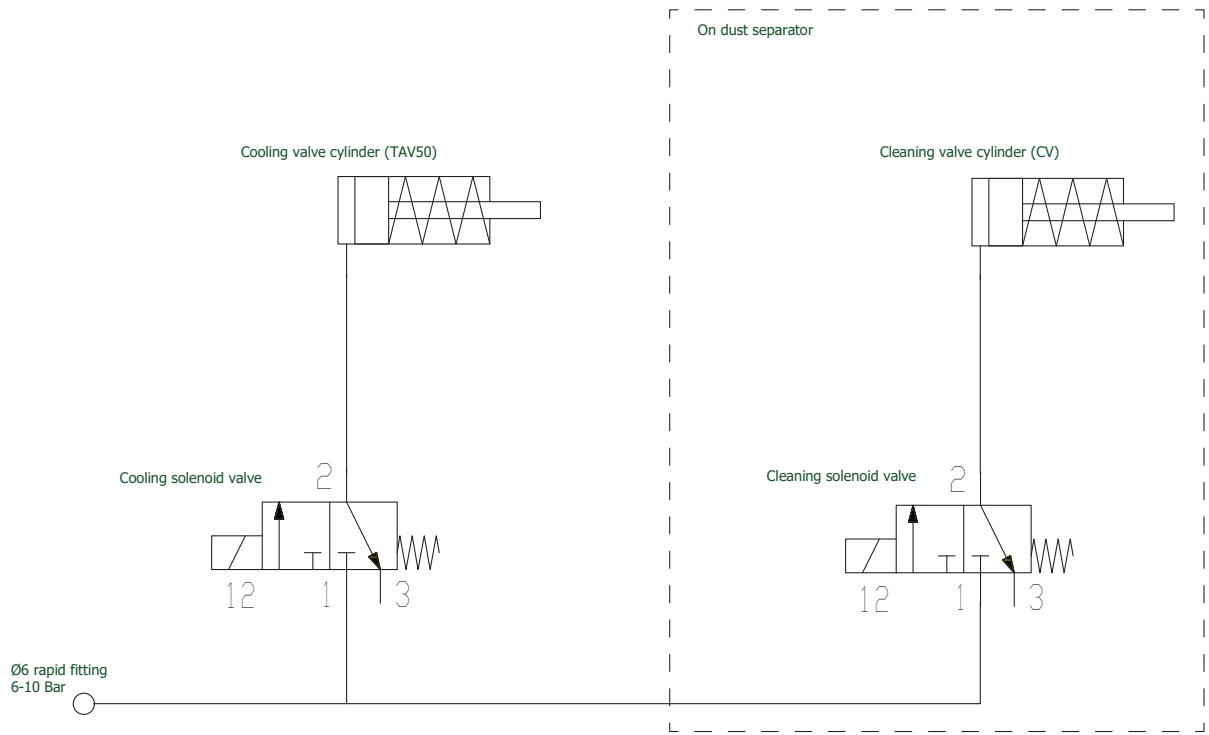

1 Preface and safety

Read all product documentation and the product identification plate carefully before installation, use, and service of this product. Replace documentation immediately if lost. Nederman reserves the right, without previous notice, to modify and improve its products including documentation.

This product is designed to meet the requirements of relevant EC directives. To maintain this status, all installation, maintenance, and repair is to be done by qualified personnel using only Nederman original spare parts and accessories. Contact the nearest authorized distributor or Nederman for advice on technical service and obtaining spare parts. If there are any damaged or missing parts when the product is delivered, notify the carrier and the local Nederman representative immediately.

1.1 PAK-M specifics

The Vacuum and Control unit can be used as a standalone vacuum source or be part of a complete PAK-M fitted with different dust separators, filters and accessories.

PAK-M comes in three main configurations:

- 1 A stand alone Vacuum and Control unit.
- 2 A Vacuum and Control unit with a Standard Dust Separator.
- 3 A Vacuum and Control unit with a Dust Separator in a DX/EX configuration.

The main manual is the User Manual for the stand alone Vacuum and Control unit. Other manuals are extensions of this manual. Please consider these notes:



NOTE!

- For each variant of PAK-M: Manuals are separated into User Manuals, Installation and Service Manuals, a Program Manual and accessory manuals.
- Refer to the correct manual in case of missing information. A manual generally describe the specific configuration; Dust Separator, ATEX, accessory, and so on.
- All manuals must be kept with care and made available to all persons involved in operating the equipment.
- Images in this Installation and Service Manual may differ slightly from your model.

1.2 Overall PAK-M safety

- PAK-M, including its configurations must be installed, used and maintained according to all related manuals in such a way that safety not will be neglected.
- All related manuals must be easily available, otherwise, the product will lack one of its fundamental safety requisites.



WARNING! Risk of personal injury

- Any functional disorders, especially those affecting the safety of the machine, must be rectified immediately. If improperly used, poorly connected, or altered, no matter how minor, the safety and reliability could be jeopardized.
- Grinding, welding or other hot works on PAK-M or the duct system should not be done without first stopping and cleaning the system.
- Do not collect items that may cause ignition or blocking. It is strictly prohibited to collect material that can undergo dangerous chemical or thermal reactions and/or self-ignite.
- Each PAK-M system must be dimensioned individually. To ensure that your system will be safe, a risk analysis must be performed for each installation and intended use.
- Do not make any changes to this product without consulting Nederman.
- Place fire alarms and an appropriate extinguishing system in all locations where collected dust is stored.



NOTE!

Some materials may undergo chemical reactions in combination with humidity/water. Such humidity may, for example, form if the humidity in the extracted air is condensed in the filters.

2 Installation

NOTE!

- Copy the installation protocol (appendix A), during installation, fill it in and save it as a service record. See [Chapter 4 Appendix A: Installation protocol](#).
- A value outside the limit or an incorrect/missing result is to be rectified before initial start-up and operation.

2.1 Transport and delivery check

It is recommended to transport PAK-M to the installation site while still in the factory packing. For lifting points, see [Figure 8](#).

NOTE!

- Ensure that the forks stick out at the back, so it is a level lift.
- If PAK-M needs to be moved to another location. Make sure to empty the collecting bin first.

PAK-M should be checked for any damage that may have occurred during transport. If there is damage or parts missing, the carrier and your local Nederman representative should be notified immediately.

2.2 Pre-installation

All installation is to be done by qualified personnel using only Nederman original parts and accessories.

WARNING! Risk of personal injury

- Read and follow all the applicable installation requirements during installation.
- Use proper lifting equipment and protective gear.
- Never run PAK-M without the required filters inserted.
- Do not completely seal a room where the filter is installed since the cleaning can generate dangerous negative pressure in the room.
- Adequate protective measures need to be installed if the Standard Dust Separator is placed in an elevated position. Consider its total weight.
- Place PAK-M in a sufficiently ventilated room.

The location where PAK-M is to be placed must be prepared before the installation.

- Consider the space required for use, service and maintenance, such as changing the filters. Ensure that handling is convenient.

Tilting is used to access the main filter when PAK-M is placed in an area with little access above the unit. It is only recommended as a last resort when it cannot be placed in another location. Tilting requires the support leg to be fitted.

The support leg can be left off for easier access to the collecting bin as it is mainly for transportation and tilting purposes. Then the Dust Separator functions as a leg. If the support leg is used it must be firmly anchored to the floor. See [Figure 1](#), item 4.

PAK-M shall be anchored to a hard, level and firm foundation. A general example would be a reinforced concrete foundation at least 190 mm (7,5 in) thick. When calculating for foundation or supporting structure the following factors should be considered:

- Total weight of the Vacuum and Control unit and the Dust Separator with accessories. See [Section 2.11 Technical data](#).
- Environmental and ambient conditions. See [Section 2.11 Technical data](#).
- Max weight of the collected material.
- Possible wind load.
- Recommended bolts for concrete are Hilti HDA-P/PF M10x50 or HSC-A/HSC-AR M8x50 or equivalent. If expansion bolts are to be used, the concrete foundation must be prepared according to bolt recommendations.

**NOTE!**

- PAK-M needs approx. 1000 mm of free space above the main filter to facilitate the change of it. See [Figure 3](#).
- If the ceiling is low the Dust Separator may be tilted to empty the filter. In this case, less ceiling height is required, approximately 2200 mm, as access is required to the front and back.
- PAK-M should not be installed close to heat sources or hot surfaces.
- The Vacuum and Control unit and Dust Separator are connected at delivery. If you wish to separate them, the Dust Separator should be treated as a standalone filter unit.
- Always follow local regulations and legislation for all steps in the installation process.
- Read all required product manuals before the assembly of PAK-M and pay close attention to the recommendations. Refer to the correct manual in case of missing information.
- It is recommended that a layout is made for the entire system before installation.

2.3 Main installation

**WARNING! Risk of explosion**

Do not open electrical connections when explosive atmosphere or dust is present.

**NOTE!**

Fill in the installation protocol during the installation.

- 1 Remove the factory packaging.
- 2 Position PAK-M in the installation location.
- 3 Anchor the Vacuum and Control unit and the filter housing firmly to a hard, level and firm foundation. If required, fit the support leg to the Dust Separator.
- 4 Follow the steps in related installation sections; duct, electrical and so on.

**NOTE!**

After all installation and maintenance work: verify the earth connection.

2.4 Duct installation

Consider the following when designing duct systems:

- It is important to use a correct duct diameter to avoid pressure losses and dust deposits in the system.
- Ensure that the correct transport velocity is achieved.
- Velocity should never decrease en route to the Dust Separator.
- Velocity may vary depending on how much of the vacuum system is used (infrequent use).
- Correct velocity depends on the properties of the transported material. Some composite applications can require velocities up to 25 m/s (82 ft/s).
- To keep the pipes clean a principle called "flushing" may be used. By fitting a valve at the end of the duct system each branch of the vacuum system can be flushed separately to reduce the risk of dust deposits. By not using the rest of the system, and opening the "flush valve", a high amount of air will flush the system clean.
- Do not connect several PAK-M or other vacuum sources to the same duct system. This will cause errors in the vacuum regulation and undesired behaviour.
- If the dust is abrasive it may be necessary to use thick-walled (or rubber-coated) material in bends and other exposed areas.
- To avoid pressure losses, the duct system should be as short as possible and designed with two or more branches. Use larger diameters on the clean side to reduce pressure losses.
- Length to the suction source should be less than 25 meters.

**NOTE!**

This will affect capacity due to pressure drops, see [Figure 9](#) and [Figure 10](#) and the User Manual for the Vacuum and Control unit.

2.5 Electrical installation

- Solenoid on cleaning valve. See [Figure 4](#), item CV.

- Cleaning valve operation; 24 V DC, Signal opens the valve.

WARNING! Risk of personal injury

- Global as well as national and local electric regulations must be fulfilled.
- The electrical installation must be done by a certified electrician. Use electrical diagrams.
- Correct voltage must be connected. Control signals must be fused, maximum 5A, to avoid heating of cables and equipment in case of damage, short circuit or malfunction.
- Always replace worn, faulty or defective electrical components with new original parts.
- Check that proper measures have been taken to avoid all types of electrical stray currents to and/or from the piping system and electrical wiring.
- A lightning conductor must be installed if PAK-M is installed outdoors.

2.6 Compressed air installation

See [Figure 11](#) and [Section 2.11 Technical data](#).

WARNING! Risk of personal injury

Use ear protection and safety goggles.

- Cleaning Valve (CV), Cleaning Cylinder (CC).

Consider the following:

- As new ducts may contain dirt/particles/debris, the compressed air duct should be blown clean before connecting PAK-M.
- A compressed air filter must be installed to ensure safe operation of PAK-M. A main valve that bleeds the remaining pressure should be installed.
- It is recommended that a pressure switch, warning for insufficient pressure, is connected to the control system.
- The specified air consumption of PAK-M is limited to the short operation of the cleaning valve.
- Take necessary measures to avoid water/humidity in the compressed air when installed in cold environments.
- If anti-freeze additives are used, ensure continuous use. Once added, the removal of the anti-freeze additive can cause malfunction of the pneumatic components.
- To avoid personal injuries during maintenance, the main valve should be locked in a closed position.
- Use black tubing to differentiate compressed air from pressure measurements.

2.7 Installing a secondary filter

See [Figure 6](#).

- 1 Disconnect the outlet hose, item 1A, from the Vacuum and Control unit.
- 2 Fit the secondary filter housing on the inlet of the Vacuum and Control unit. Turn and align, so the inlet to the secondary filter housing is directed towards the outlet of the Dust Separator.

NOTE!

Item 2 shows the filter with the lid removed.

- 3 Fit the bracket between secondary filter housing and leg bracket on the Dust Separator, item 3B.
- 4 Connect the shorter hose between the secondary filter and the outlet of the Dust Separator, item 4C.

2.8 Main parts

See User Manual and [Figure 1](#).

2.9 Accessories

Nederman is prepared for Nederman accessories and customer connections.

The installation of accessories, extra equipment, and functions are described in the manual for each product and according to the electrical diagrams that came with it. Consult your local Nederman representative for available accessories.

2.10 Pressure measuring points and connections

Figure 4 shows the pressure measuring points and connections.

P1: Pressure sensing tube. Pressure measuring point for pressure upstream main filter, Ø 6 mm (0.24 ")

P2: Pressure sensing tube. Pressure measuring point for pressure downstream main filter, Ø 6 mm (0.24 ")

CV: Cleaning Valve, Ø 6 mm (0.24 ")

CC: Cleaning Cylinder



CAUTION! Risk of equipment damage

- Do not switch connections for pressure measuring points.
- Blue tubes are used for measuring and black for compressed air.

2.11 Technical data

PAK-M with Standard Dust Separator	
Capacity and pressure drop* :	Flow is shown in m ³ /h and pressure/pressure drop in kPa/Pa
- Capacity PAK-M	See Figure 9 , item A
- Capacity PAK-M with secondary filter	See Figure 9 , item B
- Pressure drop P1-P2 (main filter)	See Figure 10 , item A
- Pressure drop P2-P3 (secondary filter)	See Figure 10 , item B
- Pressure drop Dust Separator without secondary filter	See Figure 10 , item C
- Pressure drop Dust Separator with secondary filter (H14)	See Figure 10 , item D
Process air (dry) temperature	See the User Manual for the Vacuum and Control unit
Operating temperature	See the User Manual for the Vacuum and Control unit
Main filter, area	3,4 m ² (36.6 sqft)
Main filter, material	Polyester with PTFE coating
Main filter, material efficiency	Class M according to EN 60335-2-69
Secondary filter (optional):	See Figure 1 , item 7
- Area	6,16 m ² (66.3 sqft)
- Material	3 layer, polyester/glass fibre/polyester
- Efficiency	HEPA H14 (99.995% MPPS)
Protection class PAK-M	IP54
Weight Dust Separator, approx:	70 kg (154 lb)
Weight PAK-M with Standard Dust Separator, approx:	253 kg (558 lb)

PAK-M with Standard Dust Separator	
Dimensions:	See Figure 2
- Inlet, Dust Separator (A)	Ø 100 mm (3.94 ")
- Outlet, Dust Separator (B)	Ø 100 mm (3.94 ")
- Inlet, Vacuum and Control unit (C)	Ø 100 mm (3.94 ")
- Outlet, Vacuum and Control unit (D)	Ø 100 mm (3.94 ")
Compressed air connection	Ø6 mm (0.24 ")
Compressed air quality	Clean dry, ISO 8573-1 class 5
Compressed air pressure	6 - 10 bar (87 - 145 PSI)
Max air consumption (intermittent during filter cleaning)	700 N-Litres/min (25 cfm)
Control voltage Dust Separator	24 V DC ± 10%
Material Dust Separator	Powder coated steel
Corrosion protection level Dust Separator	C2 according to ISO 12944-2
Material recycling Dust Separator, approx	98 weight-%
Collecting bin volume	70l

* New clean filters. See the Vacuum and Control unit User Manual for max pressure set point.

3 Service and maintenance



WARNING! Risk of personal injury

- Maintenance work in elevated positions requires adequate safety measures.
- Use proper protective equipment where there is a risk of exposure to dust.
- Use proper lifting equipment and protective gear.
- Wear ear protection when work is carried out near the upper section of the Dust Separator.
- The compressed air supply needs to be securely disconnected during service and maintenance.
- Avoid spilling materials.
- After all installation and maintenance work: verify the earth connection.



WARNING! Risk of explosion

Before performing any grinding, welding or other hot works on PAK-M, stop operation and clean all parts in contact with dust: filter housing, filters, collecting bin and so on.



NOTE!

Fill out the service protocol for all maintenance performed on PAK-M. See [Chapter 5 Appendix B: Service protocol](#).

3.1 Maintenance schedule

Type of maintenance	Frequency
Regular inspection	Regularly and after changed operating conditions
Yearly inspection	One month after installation and every year
Main filter change	6000 hours

3.2 Inspections

At least yearly:

- 1 Inspect all parts of PAK-M and pay special attention to the seals for the collecting bin and main filter. Also inspect the steel clamping rings holding together the housing/inlet/cone-modules. Replace damaged parts.
- 2 Check all parts of all attachments. Tighten bolts if necessary.
- 3 Make sure the outside, particularly the solenoids, sensors and connection box, are free from dust layers.
- 4 Make sure the inside of PAK-M and the connection pipes are free from deposits.
- 5 Clean the area around PAK-M, including all areas where the collected material is stored to ensure that there are no dust deposits.
- 6 Check that all signs/markings regarding safe operation are in place and that personnel know about them.

3.3 Changing the main filter package or replacing a filter bag in the main filter

The main filter should normally be replaced after 6000 hours of operation or when damaged. It should also be replaced if the filter function is insufficient.

The Dust Separator can be tilted if there is no clearance above to remove the filter. See [Section 3.4 Tilting the Dust Separator](#).



NOTE!

- Individual replacement of filter bags is possible but replacing the whole main filter package, including the filter panel and locking rings, is recommended as it is quicker and causes less spreading of dust.
- Replacement of filters should be registered in the Service protocol.

**WARNING! Risk of personal injury**

- Never run PAK-M without the required filters inserted.
- The vacuum and compressed air must be turned off before commencing a filter change.
- Use proper lifting equipment and protective gear.

3.3.1 Changing the main filter package

- 1 Disconnect the outlet hose from the outlet.
- 2 Disconnect the pneumatic 3/2 cleaning valve from CV.
- 3 Remove the pressure sensing tubes, see [Figure 4](#), items P1 and P2. Continue with other added connections.
- 4 Remove the lid from the outlet.
- 5 Take out the main filter package and put it in a large plastic bag, or wrap it in plastic foil to avoid dust spreading.
- 6 Fit the new filter package.
- 7 Reconnect the pressure sensing tubes, pneumatic valve and outlet hose.

3.3.2 Changing a filter bag in the main filter

Individual main filter bags that have been damaged can be replaced.

- 1 Use a screwdriver to detach the plastic locking ring and remove the old filter bag including the coiled spring, see [Figure 7](#), item A.
- 2 Insert the new filter bag including the coiled spring.
- 3 Attach a new plastic locking.

**NOTE!**

- A certain quantity of fine particles on the filter bags improves particle separation compared to using clean bags.
- The coiled spring can be reused with the new filter bag, but the locking ring must be replaced when securing the new filter bag, see [Figure 7](#), item B.
- Never re-use an old locking ring.

3.4 Tilting the Dust Separator**WARNING! Risk of personal injury**

- Avoid placing PAK-M in an area that requires the Dust Separator to be tilted to access the main filter, consider it a last resort. Do a risk assessment before tilting.
- Use proper lifting equipment and protective gear.
- The support leg must be firmly anchored to the floor. See [Figure 1](#), item 4.

**NOTE!**

- Tilting requires the support, accessory, leg to be fitted.
- You need to make a gap of around 4 mm between the leg and the Vacuum and Control unit in order to tilt the filter.
- How to remove the Vacuum and Control unit panels is described in the Installation and Service Manual for the Vacuum and Control unit.

The Dust Separator tilts and swivels around two M16 bolts.

- 1 Remove ducting from the inlet.
- 2 Follow steps 1-3 in [Section 3.3.1 Changing the main filter package](#) for a filter change.
- 3 Remove the required Vacuum and Control unit panels.
- 4 Ensure that the M16 bolts are not tightened so the Dust Separator can pivot around them. Loosen to a gap of around 3 mm.
- 5 Remove the four M12 bolts in the bracket. See [Figure 5](#), items A.
- 6 Turn the filter housing by releasing the push-in lock pin. See [Figure 5](#), item B.
- 7 Rotate the filter housing 90°. The lock pin will automatically lock the position.
- 8 Follow steps 4-6 in [Section 3.3.1 Changing the main filter package](#).

- 9 Tilt the Dust Separator back into an upright position and fit the four M12 bolts on each side. See [Figure 5](#), items A.
- 10 Reconnect the ducting to the inlet.

3.5 Changing the secondary filter

See [Figure 6](#).

- 1 Disconnect the outlet hose, item 4C, from the Dust Separator.
- 2 Open the four locks on the filter housing, items 2D, and remove the lid.

**NOTE!**

Item 2 shows the filter with the lid removed.

- 3 Thread a plastic bag over the secondary filter housing and lift out the filter, item 2E, inside the plastic bag.
- 4 Fit the new filter.
- 5 Fit the lid.
- 6 Reconnect the outlet hose.

4 Appendix A: Installation protocol

Type (PAK-M, PAK-M DX or PAK-M VAC):	Performed by:
--------------------------------------	---------------

Date:	Art. No.:	Serial No.:
-------	-----------	-------------

Control item	Yes	No	Comment
Transport damages			
All components delivered			
Machine label matches the order			
Required User Manuals included			
Required Installation and Service Manuals included			
Factory test report included			
Radiation heat from surroundings is low			
Protection from wind, rain, snow, dust, etc. is good			
Foundation is according to specifications (can withstand total weight and strain on bolts)			
Ambient temperature is within range			
Access for service and maintenance			
Ventilation openings in the installation room are as specified			
Cooling intakes are free from blocking			
Process air temperature is within range			
Earth leakage circuit breaker works with VFD			
All power cables are adequately tightened			
Pilot signal is used			
Maintenance switch is used			
Compressed air tubes are cleaned and connected			
Compressed air is clean and dry			
A shut-off valve is installed for compressed air			
Inlet and outlet ducts are connected			
Accessories are installed			
Signs and warnings are appropriate			

Control item	Yes	No	Comment
Measuring tubes, P1, P2 and P3 are functioning			
Emergency stop works as expected			
Reset works as intended			
Vacuum reads expected value			
Filter cleaning works as intended			
Temperature reads expected value			
Date & time is set (if week timer is used)			

Electrical values

Mains voltage (V):	Mains fuse size (A):
Mains frequency (Hz):	Mains fuse type:

Vacuum levels

Ambient temp., derating value (kPa):	Main filter DPS1 set point (kPa):
Process air temp., derating value (kPa):	Secondary filter DPS2 set point, if used (kPa):
Altitude derating value (kPa):	Vacuum level (PID) setting (kPa):
Exhaust ducting length & size resistance (kPa):	Vacuum level at fan (kPa) *:
Other resistance in exhaust ducting (kPa):	

* Compare with max in technical data

5 Appendix B: Service protocol

Type (PAK-M, PAK-M DX or PAK-M VAC):	Performed by:
--------------------------------------	---------------

Date:	Art. No.:	Serial No.:
-------	-----------	-------------

Control item	Yes	No	Comment
Radiation heat from surroundings is low			
Protection from wind, rain, snow, dust, etc. is good			
Foundation is according to specifications (can withstand total weight and strain on bolts)			
Ambient temperature is within range			
Access for service and maintenance			
Ventilation openings in the installation room are as specified			
Cooling intakes are free from blocking			
Dust deposits in work area			
Dust deposits inside			
Inlet and outlet ducts are connected			
Signs and warnings are appropriate			
VFD reads expected temperature value			
Compressed air shut-off valve is installed			
Compressed air pressure is correct			
Maintenance switch works as intended			
Mains fuse is correct type and size			
All power cables are adequately tightened			
Changes in duct system since installation (including exhaust)			
Changes in ambient conditions since installation			
Emergency stop works as expected			
Reset works as intended			
Cooling valve tested (optional)			
Filter cleaning works as intended			
Start and run is normal			

Vacuum levels

Main filter DPS1 set point (kPa):

Measured duct pressure (kPa):

Secondary filter DPS2 set point, if used (kPa):

Measured pressure (P3B/DPS2) at fan (kPa) *:

Vacuum level (PID) setting (kPa):

* Compare with max in technical data and installation protocol

Additional notes

1.

2.

3.

4.

5.

Nederman

www.nederman.com