

MOUNTING INSTRUCTION

Machinery Stand including Damper for NOM 4 Filter Unit

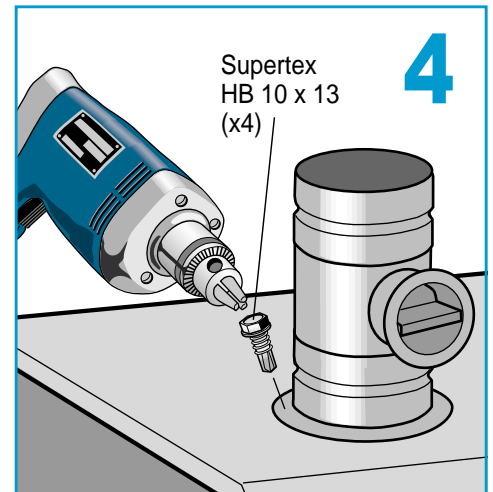

Adjust the rubber feet, if necessary, to make sure that the damper fits in a proper way against the filter unit.

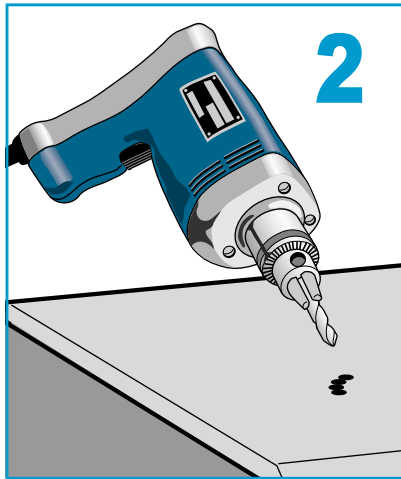
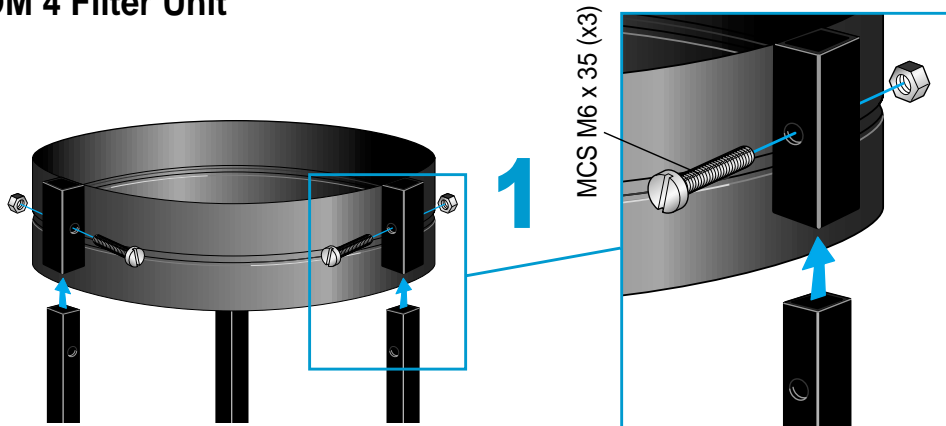
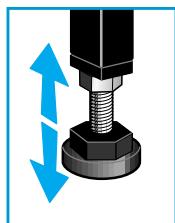

To fit different machines it could be necessary to cut one or two legs to other lengths.

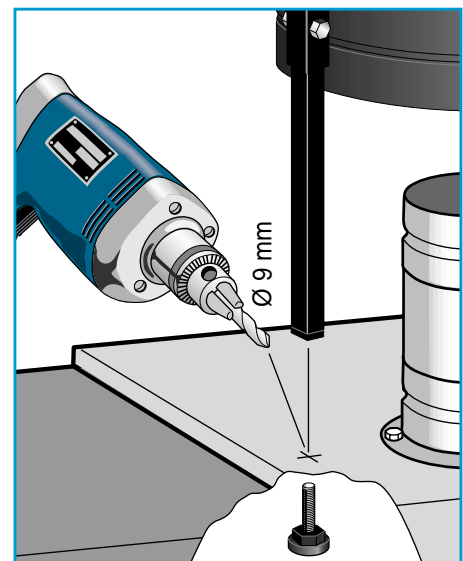

As an alternative the legs can be fixed with screws to the machinery.

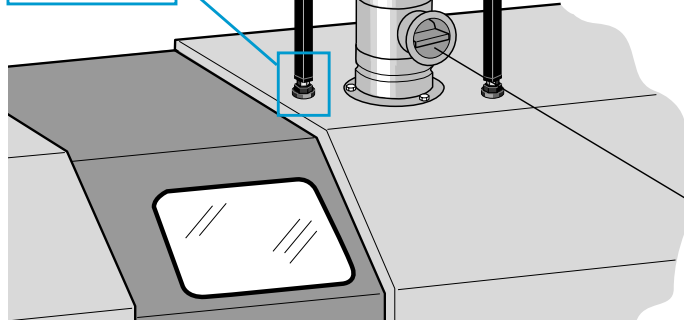

When the filter unit has been started, the damper should be opened approximately 1/3 from closed position (marked 60°). After some time in operation, open the damper more if needed.